



GST NO.: 29AHZPU5620Q1ZZ

An ISO 9001:2015 Certified Company

# ROYAL INDUSTRIAL SUPPLIERS

QUALITY FASTENERS SPECIALIST



8310165941 / 9959457863



sales@royalfastenersindia.com



www.royalfastenersindia.com

## TECHNICAL DATA SHEET

### CONTACT LOCK WASHER



MATERIAL- STAINLESS STEEL

GRADE-SS316 A4

AS PER-NFE-25-511

CATALOGUE NO. R6G44C

### INSTALLATION GUIDE

- VERIFY THE CONTACT LOCK WASHER SIZE MATCHES THE FASTENER DIAMETER AND APPLICATION REQUIREMENT.
- INSPECT THE WASHER FOR PROPER TOOTH FORM, DAMAGE, OR CORROSION BEFORE INSTALLATION.
- ENSURE THE CONTACT SURFACES ARE CLEAN, DRY, AND FREE FROM PAINT, OIL, OR OXIDATION.
- POSITION THE CONTACT LOCK WASHER BETWEEN THE FASTENER HEAD OR NUT AND THE MATING SURFACE.
- ENSURE THE TEETH FACE THE CONTACT SURFACE TO PROVIDE EFFECTIVE LOCKING AND ELECTRICAL CONTACT.
- ALIGN THE WASHER PROPERLY AROUND THE FASTENER SHANK.
- INSERT THE FASTENER THROUGH THE WASHER AND INTO THE MATING THREAD OR NUT.
- HAND-TIGHTEN INITIALLY TO ENSURE CORRECT POSITIONING.
- TIGHTEN THE FASTENER TO THE SPECIFIED TORQUE USING THE APPROPRIATE TOOL.
- ALLOW THE WASHER TEETH TO BITE INTO THE MATING SURFACES.
- ENSURE FULL METAL-TO-METAL CONTACT IS ACHIEVED FOR RELIABLE GROUNDING OR BONDING.
- DO NOT OVERTIGHTEN, AS EXCESSIVE FORCE MAY FLATTEN THE TEETH AND REDUCE EFFECTIVENESS.
- VERIFY THAT THE FASTENER IS SECURE AND RESISTANT TO LOOSENING DUE TO VIBRATION INSPECT THE FINAL ASSEMBLY FOR PROPER SEATING, ELECTRICAL CONTINUITY, AND MECHANICAL LOCKING.

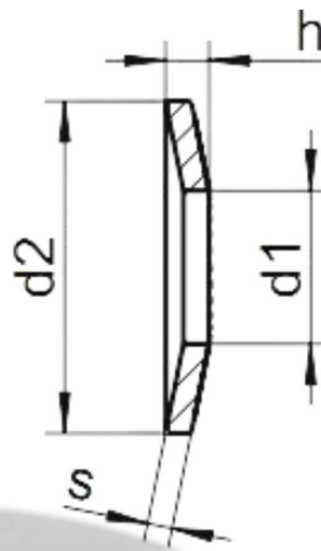
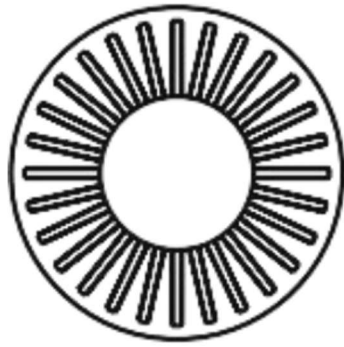

**TYPE-M FOR HEX SCREW AND BOLTS**



Quote the PART NUMBER given below with your order/ inquiries:

All Dimensions in mm

Nominal Size	Item Code	Inside Diameter d1		Outside Diameter d2		Height h		Thickness s	
		Min	Max	Min	Max	Min	Max	Min	Max
<b>M3</b>	<b>R6G44C03000</b>	3.1	3.35	7.71	8.29	0.80	1.00	0.57	0.63
<b>M4</b>	<b>R6G44C04000</b>	4.1	4.4	9.71	10.29	1.15	1.40	0.86	0.94
<b>M5</b>	<b>R6G44C05000</b>	5.1	5.4	11.65	12.35	1.45	1.80	1.06	1.14
<b>M6</b>	<b>R6G44C06000</b>	6.1	6.4	13.65	14.35	1.75	2.10	1.26	1.34
<b>M8</b>	<b>R6G44C08000</b>	8.2	8.56	17.65	18.35	1.90	2.35	1.36	1.44
<b>M10</b>	<b>R6G44C10000</b>	10.2	10.56	21.58	22.42	2.25	2.75	1.55	1.65
<b>M12</b>	<b>R6G44C12000</b>	12.4	12.83	26.58	27.42	2.60	3.10	1.75	1.85
<b>M14</b>	<b>R6G44C14000</b>	14.4	14.81	29.58	30.42	3.20	3.70	2.34	2.46
<b>M16</b>	<b>R6G44C16000</b>	16.4	16.83	31.50	32.50	3.60	4.10	2.74	2.86
<b>M20</b>	<b>R6G44C20000</b>	20.5	21.02	39.50	40.50	4.90	4.90	3.14	3.26

Sizes in BLUE are non-preferred. Availability is limited and MOQ is applied. *Data is strictly informative*

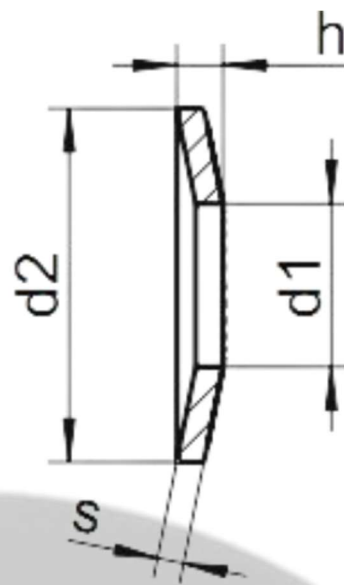
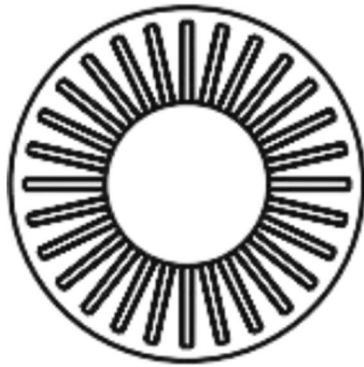

### TYPE-S FOR CYLINDRICAL HEAD SCREW

Quote the PART NUMBER given below with your order/ inquiries:

All Dimensions in mm

Nominal Size	Item Code	Inside Diameter d1		Outside Diameter d2		Height h		Thickness s	
		Min	Max	Min	Max	Min	Max	Min	Max
M3	R6G44C03001	3.1	3.35	5.76	6.24	0.70	0.90	0.47	0.53
M4	R6G44C04001	4.1	4.4	7.71	8.29	1.00	1.20	0.77	0.83
M5	R6G44C05001	5.1	5.4	9.71	10.29	1.25	1.50	0.96	1.04
M6	R6G44C06001	6.1	6.4	11.65	12.35	1.55	1.85	1.16	1.24
M8	R6G44C08001	8.1	8.56	15.65	16.35	1.80	2.20	1.36	1.44
M10	R6G44C10001	10.2	10.56	19.58	20.42	2.10	2.60	1.55	1.65
M12	R6G44C12001	12.4	12.83	23.58	24.42	2.40	2.90	1.75	1.85

Sizes in BLUE are non-preferred. Availability is limited and MOQ is applied. *Data is strictly informative*

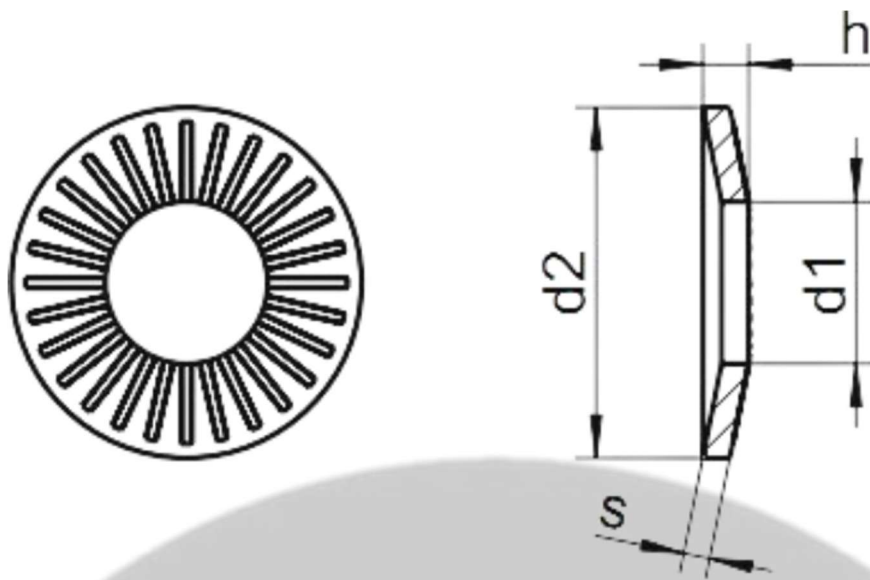

**TYPE-L FOR OVEL HOLES AND SOFT MATERIAL**

Quote the PART NUMBER given below with your order/ inquiries:

All Dimensions in mm

Nominal Size	Item Code	Inside Diameter d1		Outside Diameter d2		Height h		Thickness s	
		Min	Max	Min	Max	Min	Max	Min	Max
<b>M3</b>	<b>R6G44C03002</b>	3.10	3.35	9.65	10.35	0.95	1.20	0.57	0.63
<b>M4</b>	<b>R6G44C04002</b>	4.10	4.40	13.65	14.35	1.40	1.80	0.96	1.04
<b>M5</b>	<b>R6G44C05002</b>	5.10	5.40	15.65	16.35	1.70	2.10	1.16	1.24
<b>M6</b>	<b>R6G44C06002</b>	6.10	6.40	17.65	18.35	2.10	2.50	1.36	1.44
<b>M8</b>	<b>R6G44C08002</b>	8.10	8.56	21.48	22.42	2.20	2.70	1.55	1.65
<b>M10</b>	<b>R6G44C10002</b>	10.20	10.56	26.58	27.42	2.60	3.10	1.75	1.85
<b>M12</b>	<b>R6G44C12002</b>	12.40	12.83	31.50	32.50	3.10	3.60	1.95	2.05

Sizes in BLUE are non-preferred. Availability is limited and MOQ is applied. *Data is strictly informative*