



ROYAL INDUSTRIAL SUPPLIERS

QUALITY FASTENERS SPECIALIST



8310165941 / 9959457863



sales@royalfastenersindia.com



www.royalfastenersindia.com

TECHNICAL DATA SHEET

ALLEN GRUB SCREW CUP POINT



MATERIAL- STAINLESS STEEL

GRADE-SS304 (A2-70)

AS PER- ASME B18.3.4

CATALOGUE NO. R4C40u

INSTALLATION GUIDE

- SELECT THE CORRECT SIZE OF ALLEN GRUB SCREW CUP POINT AND MATCHING ALLEN (HEX) KEY OR DRIVER.
- ENSURE THE MATING HOLE OR THREADED COMPONENT IS CLEAN AND FREE FROM DUST, OIL, OR DEBRIS.
- ALIGN THE COMPONENTS OR SHAFT AND HUB ACCURATELY BEFORE INSTALLATION.
- INSERT THE GRUB SCREW INTO THE THREADED HOLE BY HAND TO START THREADING.
- PLACE THE ALLEN KEY OR DRIVER FIRMLY INTO THE HEX SOCKET OF THE GRUB SCREW.
- TURN THE DRIVER CLOCKWISE TO TIGHTEN THE SCREW SECURELY.
- APPLY STEADY AND CONTROLLED TORQUE TO ALLOW THE CUP POINT TO BITE INTO THE MATING SURFACE.
- ENSURE THE GRUB SCREW IS FLUSH OR SLIGHTLY BELOW THE SURFACE AFTER INSTALLATION.
- AVOID OVERTIGHTENING TO PREVENT THREAD DAMAGE OR DEFORMATION OF THE SHAFT SURFACE.
- IF REQUIRED, USE THREAD-LOCKING ADHESIVE FOR VIBRATION RESISTANCE AND LONG-TERM SECURITY.
- VERIFY THAT THE GRUB SCREW FIRMLY HOLDS THE COMPONENT IN PLACE WITHOUT ANY MOVEMENT.

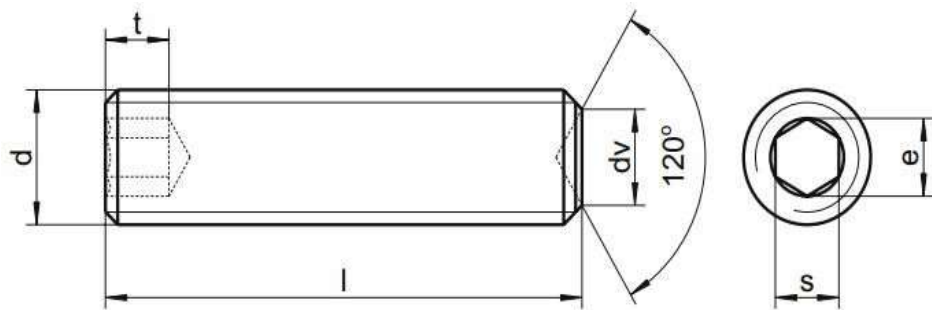

UNC SERIES

Size→	#2-56	#4-40	#6-32	#8-32	#10-24	1/4"-20	
cup dia dv	max	0.047	0.061	0.074	0.087	0.102	0.132
	min	0.039	0.051	0.064	0.076	0.088	0.118
socket depth t	0.06	0.07	0.08	0.09	0.1	0.125	
socket s	0.035	0.050	0.062	0.078	0.094	0.125	
Key Size	0.035	0.050	1/16	5/64	3/32	1/8	

Quote the PART NUMBER given below with your order/ inquiries:

All Dimensions in Inches

Size→ Length↓	#2-56	#4-40	#6-32	#8-32	#10-24	1/4"-20
3/32"	R4C40u25624	R4C40u44024				
1/8"	R4C40u25632	R4C40u44032	R4C40u63232			
5/32"	R4C40u25639	R4C40u44039	R4C40u63239	R4C40u83239		
3/16"	R4C40u25648	R4C40u44048	R4C40u63248	R4C40u83248		
1/4"	R4C40u25662	R4C40u44062	R4C40u63262	R4C40u83262		
5/16"	R4C40u25679	R4C40u44079	R4C40u63279	R4C40u83279	R4C40u12479	R4C40u62079
3/8"	R4C40u25691	R4C40u44091	R4C40u63291	R4C40u83291	R4C40u12491	R4C40u62091
1/2"	R4C40u25613	R4C40u44013	R4C40u63213	R4C40u83213	R4C40u12413	R4C40u62013
5/8"	R4C40u25615	R4C40u44015	R4C40u63215	R4C40u83215	R4C40u12415	R4C40u62015
3/4"	R4C40u25619	R4C40u44019	R4C40u63219	R4C40u83219	R4C40u12419	R4C40u62019
7/8"	R4C40u25623	R4C40u44023	R4C40u63223	R4C40u83223	R4C40u12423	R4C40u62023
1"	R4C40u25625	R4C40u44025	R4C40u63225	R4C40u83225	R4C40u12425	R4C40u62025
1 1/8"		R4C40u44028	R4C40u63228	R4C40u83228	R4C40u12428	R4C40u62028
1 1/4"		R4C40u44031	R4C40u63231	R4C40u83231	R4C40u12431	R4C40u62031
1 1/2"		R4C40u44038	R4C40u63238	R4C40u83238	R4C40u12438	R4C40u62038
1 5/8"		R4C40u44041	R4C40u63241	R4C40u83241	R4C40u12441	R4C40u62041
1 3/4"		R4C40u44044	R4C40u63244	R4C40u83244	R4C40u12444	R4C40u62044
2"		R4C40u44051	R4C40u63251	R4C40u83251	R4C40u12451	R4C40u62051

Sizes in BLUE are non-preferred. Availability is limited and MOQ is applied.

Data is strictly informative

Note: All Austenitic Stainless-Steel Fasteners may exhibit some Magnetic Properties due to the Manufacturing Process.

Refer: ISO 3506-2 Annex F