



ROYAL INDUSTRIAL SUPPLIERS

QUALITY FASTENERS SPECIALIST



8310165941 / 9959457863

sales@royalfastenersindia.com

www.royalfastenersindia.com

TECHNICAL DATA SHEET

ALLEN GRUB SCREW CUP POINT



MATERIAL- STAINLESS STEEL

GRADE-SS304 (A2-70)

AS PER- ASME B18.3.4

CATALOGUE NO. R4C40v

INSTALLATION GUIDE

- SELECT THE CORRECT SIZE OF ALLEN GRUB SCREW CUP POINT AND MATCHING ALLEN (HEX) KEY OR DRIVER.
- ENSURE THE MATING HOLE OR THREADED COMPONENT IS CLEAN AND FREE FROM DUST, OIL, OR DEBRIS.
- ALIGN THE COMPONENTS OR SHAFT AND HUB ACCURATELY BEFORE INSTALLATION.
- INSERT THE GRUB SCREW INTO THE THREADED HOLE BY HAND TO START THREADING.
- PLACE THE ALLEN KEY OR DRIVER FIRMLY INTO THE HEX SOCKET OF THE GRUB SCREW.
- TURN THE DRIVER CLOCKWISE TO TIGHTEN THE SCREW SECURELY.
- APPLY STEADY AND CONTROLLED TORQUE TO ALLOW THE CUP POINT TO BITE INTO THE MATING SURFACE.
- ENSURE THE GRUB SCREW IS FLUSH OR SLIGHTLY BELOW THE SURFACE AFTER INSTALLATION.
- AVOID OVERTIGHTENING TO PREVENT THREAD DAMAGE OR DEFORMATION OF THE SHAFT SURFACE.
- IF REQUIRED, USE THREAD-LOCKING ADHESIVE FOR VIBRATION RESISTANCE AND LONG-TERM SECURITY.
- VERIFY THAT THE GRUB SCREW FIRMLY HOLDS THE COMPONENT IN PLACE WITHOUT ANY MOVEMENT.

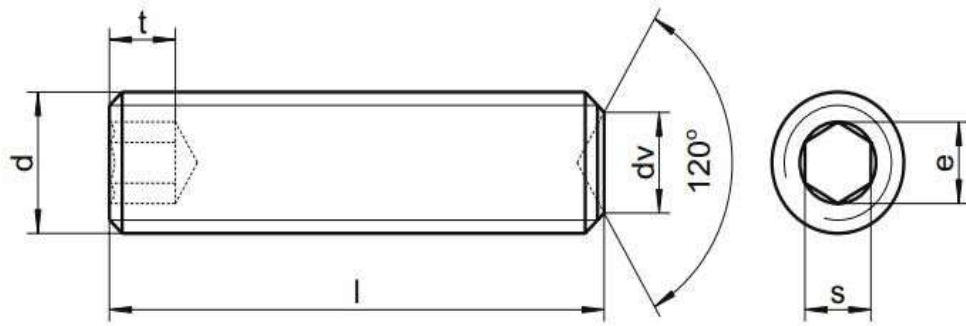

UNF SERIES

Size→	2-64	4-48	6-40	8-36	10-32	1/4-28	
cup dia dv	max	0.047	0.061	0.074	0.087	0.102	0.132
	min	0.039	0.051	0.064	0.076	0.088	0.118
socket depth t	0.06	0.07	0.08	0.09	0.1	0.125	
socket s	0.035	0.050	0.062	0.078	0.094	0.125	
Key Size	0.035	0.050	1/16	5/64	3/32	1/8	

Quote the PART NUMBER given below with your order/ inquiries:

All Dimensions in Inches

Length↓ Size→	2-64	4-48	6-40	8-36	10-32	1/4-28
3/32"	R4C40v26424	R4C40v44824				
1/8"	R4C40v26432	R4C40v44832	R4C40v64032			
5/32"	R4C40v26439	R4C40v44839	R4C40v64039	R4C40v83639		
3/16"	R4C40v26448	R4C40v44848	R4C40v64048	R4C40v83648	R4C40v13248	
1/4"	R4C40v26462	R4C40v44862	R4C40v64062	R4C40v83662	R4C40v13262	R4C40v62062
5/16"	R4C40v26479	R4C40v44879	R4C40v64079	R4C40v83679	R4C40v13279	R4C40v62079
3/8"	R4C40v26491	R4C40v44891	R4C40v64091	R4C40v83691	R4C40v13291	R4C40v62091
1/2"	R4C40v26413	R4C40v44813	R4C40v64013	R4C40v83613	R4C40v13213	R4C40v62013
5/8"	R4C40v26415	R4C40v44815	R4C40v64015	R4C40v83615	R4C40v13215	R4C40v62015
3/4"	R4C40v26419	R4C40v44819	R4C40v64019	R4C40v83619	R4C40v13219	R4C40v62019
7/8"	R4C40v26423	R4C40v44823	R4C40v64023	R4C40v83623	R4C40v13223	R4C40v62023
1"	R4C40v26425	R4C40v44825	R4C40v64025	R4C40v83625	R4C40v13225	R4C40v62025
1 1/8"		R4C40v44828	R4C40v64028	R4C40v83628	R4C40v13228	R4C40v62028
1 1/4"		R4C40v44831	R4C40v64031	R4C40v83631	R4C40v13231	R4C40v62031
1 1/2"		R4C40v44838	R4C40v64038	R4C40v83638	R4C40v13238	R4C40v62038
1 5/8"		R4C40v44841	R4C40v64041	R4C40v83641	R4C40v13241	R4C40v62041
1 3/4"		R4C40v44844	R4C40v64044	R4C40v83644	R4C40v13244	R4C40v62044
2"		R4C40v44851	R4C40v64051	R4C40v83651	R4C40v13251	R4C40v62051

Sizes in BLUE are non-preferred. Availability is limited and MOQ is applied. *Data is strictly informative*