



GST NO.: 29AHZPU5620Q1ZZ

An ISO 9001:2015 Certified Company

ROYAL INDUSTRIAL SUPPLIERS

QUALITY FASTENERS SPECIALIST



8310165941 / 9959457863



sales@royalfastenersindia.com



www.royalfastenersindia.com

TECHNICAL DATA SHEET

EYE NUT



MATERIAL- STAINLESS STEEL

GRADE-SS316 (A4-70)

AS PER-DIN-582

CATALOGUE NO. R6G71

INSTALLATION GUIDE

- VERIFY THE EYE NUT SIZE, THREAD TYPE, AND LOAD RATING MATCH THE APPLICATION REQUIREMENT.
- INSPECT THE EYE NUT FOR CRACKS, DEFORMATION, CORROSION, OR OTHER DAMAGE BEFORE INSTALLATION.
- ENSURE THE MATING BOLT OR THREADED STUD IS CLEAN, STRAIGHT, AND FREE FROM THREAD DAMAGE.
- CONFIRM THAT THE SUPPORTING STRUCTURE IS CAPABLE OF SAFELY HANDLING THE INTENDED LOAD.
- THREAD THE EYE NUT ONTO THE BOLT OR STUD BY HAND TO AVOID CROSS-THREADING.
- ROTATE THE EYE NUT UNTIL IT SITS FIRMLY AGAINST THE MATING SURFACE.
- USE A SUITABLE TOOL IF NECESSARY TO ACHIEVE THE REQUIRED TIGHTNESS.
- ENSURE THE EYE IS ALIGNED IN THE DIRECTION OF THE APPLIED LOAD.
- VERIFY THAT THE EYE NUT IS FULLY SEATED AND HAS COMPLETE THREAD ENGAGEMENT.
- AVOID OVERTIGHTENING TO PREVENT THREAD DAMAGE OR DISTORTION OF THE EYE.
- DO NOT EXCEED THE SPECIFIED WORKING LOAD LIMIT OF THE EYE NUT.
- AVOID SHOCK LOADING OR SUDDEN IMPACT LOADS DURING OPERATION.
- CHECK THAT THE LOAD IS EVENLY APPLIED AND DOES NOT CAUSE EXCESSIVE ANGULAR STRESS.
- INSPECT THE FINAL INSTALLATION TO CONFIRM SECURE FITMENT, PROPER ALIGNMENT, AND SAFE LOAD HANDLING.
- PERFORM PERIODIC INSPECTIONS TO ENSURE CONTINUED SAFETY AND RELIABILITY IN SERVICE.

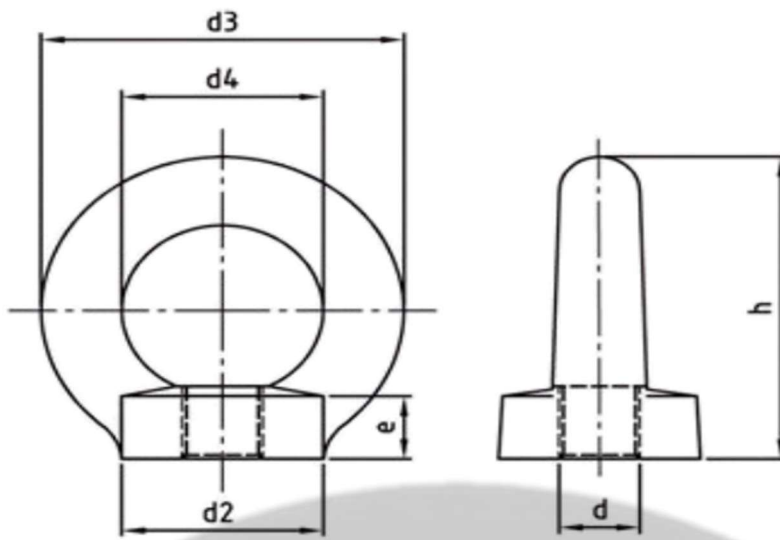

Quote the PART NUMBER given below with your order/ inquiries:

All Dimensions in mm

Nominal Size(d)	Item Code	Body Dia	Eye Outer Dia	Eye Inner Dia	Height	Body Height
Thread Size	PART NUMBER	d2	d3	d4	h	e
M6x1.0	R6G7106000	16.00	27.00	16.00	31.00	8.00
M8x1.25	R6G7108000	20.00	36.00	20.00	36.00	8.50
M10x1.5	R6G7110000	25.00	45.00	25.00	45.00	10.00
M12x1.75	R6G7112000	30.00	54.00	30.00	53.00	11.00
M16x2.0	R6G7116000	35.00	63.00	35.00	62.00	13.00
M20x2.5	R6G7120000	40.00	72.00	40.00	71.00	16.00
M24x3.0	R6G7124000	50.00	90.00	50.00	90.00	20.00
M27x3.0	R6G7127000	65.00	108.00	60.00	109.00	22.00
M30x3.5	R6G7130000	65.00	108.00	60.00	109.00	25.00
M36x4.0	R6G7136000	75.00	126.00	70.00	128.00	30.00

Sizes in BLUE are non-preferred. Availability is limited and MOQ is applied

Data is strictly informative

Note: All Austenitic Stainless-Steel Fasteners may exhibit some Magnetic Properties due to the Manufacturing Process.

Refer: ISO 3506-2 Annex F