



GST NO.: 29AHZPU5620Q1ZZ

An ISO 9001:2015 Certified Company

ROYAL INDUSTRIAL SUPPLIERS

QUALITY FASTENERS SPECIALIST



8310165941 / 9959457863



sales@royalfastenersindia.com



www.royalfastenersindia.com

TECHNICAL DATA SHEET

HEXAGONAL NUT



MATERIAL- STAINLESS STEEL

GRADE-SS316 (A4)

AS PER- ASME B 18.2.2

CATALOGUE NO. R6D15u

UNC SERIES

INSTALLATION GUIDE

- SELECT THE CORRECT SIZE OF HEX NUT TO MATCH THE BOLT OR STUD THREAD SIZE AND PITCH.
- ENSURE BOTH THE BOLT AND NUT THREADS ARE CLEAN, DRY, AND FREE FROM DUST, OIL, OR DEBRIS.
- ALIGN THE HEX NUT WITH THE BOLT OR STUD THREAD PROPERLY BEFORE STARTING INSTALLATION.
- HAND-TIGHTEN THE HEX NUT ONTO THE BOLT OR STUD IN A CLOCKWISE DIRECTION TO START THREAD ENGAGEMENT.
- USE A SUITABLE SPANNER OR SOCKET WRENCH THAT FITS THE HEX NUT SECURELY.
- TIGHTEN THE NUT EVENLY AND GRADUALLY USING STEADY PRESSURE.
- IF MULTIPLE NUTS OR BOLTS ARE USED, FOLLOW A DIAGONAL OR CROSS-PATTERN TIGHTENING SEQUENCE.
- APPLY THE SPECIFIED TORQUE VALUE USING A TORQUE WRENCH IF REQUIRED.
- AVOID OVERTIGHTENING TO PREVENT THREAD DAMAGE OR DEFORMATION OF THE COMPONENTS.
- USE A WASHER UNDER THE NUT IF SPECIFIED TO DISTRIBUTE LOAD AND PROTECT THE SURFACE.
- FOR VIBRATION-PRONE APPLICATIONS, USE A LOCK NUT, SPRING WASHER, OR THREAD-LOCKING COMPOUND.
- VERIFY THAT THE HEX NUT IS FULLY SEATED AND THE ASSEMBLY IS SECURE AFTER INSTALLATION.

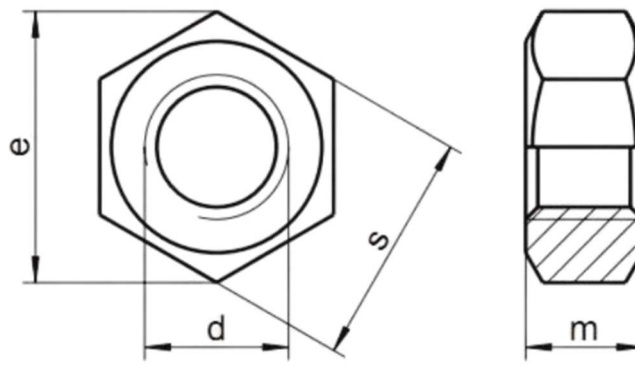

Quote the PART NUMBER given below with your order/ inquiries:

All Dimensions in Inches

Thread Size	PART NUMBER	Width Across Corners e min	Width Across flat S			Thickness m		
d			Nom	Min	Max	Nom	Min	Max
2-56	R6D15u25600	0.205	3/16"	0.180	0.188	1/16"	0.057	0.066
4-40	R6D15u44000	0.275	1/4"	0.241	0.25	3/32"	0.087	0.098
6-32	R6D15u63200	0.344	5/16"	0.302	0.312	7/64"	0.102	0.114
8-32	R6D15u83200	0.378	11/32"	0.332	0.344	1/8"	0.117	0.130
10-24	R6D15u12400	0.413	3/8"	0.362	0.375	1/8"	0.117	0.130
10-24(A)	R6D15u12410	0.413	21/64"	0.320	0.328	5/32"	0.148	0.162
12-24	R6D15u12240	0.482	7/16"	0.423	0.438	5/32"	0.148	0.161
1/4-20	R6D15u62000	0.488	7/16"	0.428	0.438	7/32"	0.212	0.226
5/16-18	R6D15u79000	0.557	1/2"	0.489	0.500	17/64"	0.258	0.273
3/8-16	R6D15u91000	0.628	9/16"	0.551	0.563	21/64"	0.320	0.337
7/16-14	R6D15u11000	0.768	11/16"	0.675	0.688	3/8"	0.365	0.385
1/2-13	R6D15u13000	0.840	3/4"	0.736	0.750	7/16"	0.427	0.448
9/16-12	R6D15u14000	1.010	7/8"	0.861	0.875	31/64"	0.473	0.496
5/8-11	R6D15u15000	1.051	15/16"	0.922	0.938	36/64"	0.535	0.559
3/4-10	R6D15u19000	1.240	1 1/8"	1.088	1.125	41/64"	0.617	0.665
7/8-9	R6D15u23000	1.447	1 5/16"	1.269	1.312	3/4"	0.724	0.776
1-8	R6D15u25000	1.653	1 1/2"	1.450	1.500	55/64"	0.831	0.888
1 1/8-7	R6D15u28000	1.859	1 11/16"	1.631	1.688	31/32"	0.939	0.999
1 1/4-7	R6D15u31000	2.066	1 7/8"	1.812	1.875	1 1/16"	1.030	1.094
1 1/2-6	R6D15u38000	2.480	2 1/4"	2.175	2.250	1 9/32"	1.245	1.317

Sizes in BLUE are non-preferred. Availability is limited and MOQ is applied *Data is strictly informative*

Note: All Austenitic Stainless-Steel Fasteners may exhibit some Magnetic Properties due to the Manufacturing Process.

Refer: ISO 3506-2 Annex F