



GST NO.: 29AHZPU5620Q1ZZ

An ISO 9001:2015 Certified Company

ROYAL INDUSTRIAL SUPPLIERS

QUALITY FASTENERS SPECIALIST



8310165941 / 9959457863



sales@royalfastenersindia.com



www.royalfastenersindia.com

TECHNICAL DATA SHEET

CARRIAGE BOLT



MATERIAL- STAINLESS STEEL

GRADE-SS304 (A2-70)

AS PER-ASME B18.5

CATALOGUE NO. R4G69u

INSTALLATION GUIDE

- VERIFY THE BOLT SIZE, LENGTH, THREAD PITCH, AND SQUARE NECK DIMENSIONS MATCH THE APPLICATION REQUIREMENT.
- INSPECT THE CARRIAGE BOLT FOR THREAD DAMAGE, CORROSION, OR SURFACE DEFECTS BEFORE INSTALLATION.
- ENSURE THE MATING HOLES ARE CORRECTLY SIZED, ALIGNED, AND FREE FROM BURRS OR DEBRIS.
- CHECK THAT THE SQUARE NECK CAN PROPERLY ENGAGE WITH THE MOUNTING HOLE OR MATERIAL.
- ALIGN THE COMPONENTS AND INSERT THE CARRIAGE BOLT THROUGH THE HOLES.
- ENSURE THE SQUARE NECK IS FULLY SEATED IN THE MATERIAL TO PREVENT BOLT ROTATION.
- PLACE THE REQUIRED WASHER AND NUT ON THE THREADED END OF THE BOLT.
- THREAD THE NUT ONTO THE BOLT BY HAND TO PREVENT CROSS-THREADING.
- USE THE APPROPRIATE SPANNER OR SOCKET TO TIGHTEN THE NUT.
- APPLY TIGHTENING FORCE GRADUALLY WHILE MAINTAINING COMPONENT ALIGNMENT.
- TIGHTEN THE ASSEMBLY TO THE SPECIFIED TORQUE VALUE.
- ENSURE THE ROUND HEAD SITS FLUSH AGAINST THE SURFACE AFTER INSTALLATION.
- DO NOT OVERTIGHTEN, AS THIS MAY DAMAGE THE MATERIAL OR THREADS.
- VERIFY THAT THE BOLT IS SECURE AND THE SQUARE NECK REMAINS ENGAGED.
- INSPECT THE FINAL ASSEMBLY FOR PROPER SEATING, ALIGNMENT, AND CLAMPING FORCE.

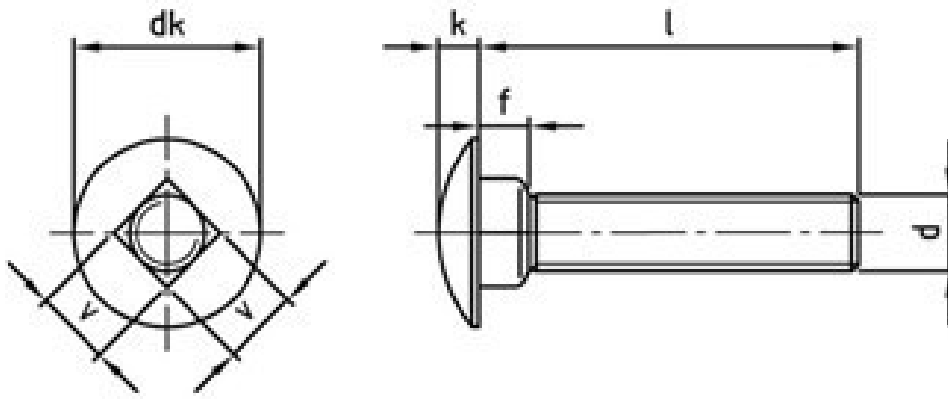

SIZE→ Parameter↓	8-32	10-24	1/4-20	5/16-18	3/8-16	1/2-13
d max	0.164	0.190	0.250	0.313	0.375	0.500
dk max	0.328	0.436	0.594	0.719	0.844	1.094
dk min	0.296	0.404	0.561	0.682	0.782	1.030
k max	0.102	0.114	0.145	0.176	0.208	0.270
k min	0.082	0.092	0.122	0.154	0.185	0.245
f max	0.110	0.127	0.158	0.190	0.222	0.286
f min	0.078	0.094	0.125	0.156	0.188	0.250
v max	0.171	0.201	0.264	0.328	0.392	0.520

Quote the PART NUMBER given below with your order/ inquiries:

All Dimensions in mm

SIZE→ Length↓	8-32	10-24	1/4-20	5/16-18	3/8-16	1/2-13
5/8"	R4G69u83215	R4G69u12415				
3/4"	R4G69u83219	R4G69u12419	R4G69u62019	R4G69u79019	R4G69u91019	
7/8"	R4G69u83223	R4G69u12423	R4G69u62023	R4G69u79023	R4G69u91023	
1"	R4G69u83225	R4G69u12425	R4G69u62025	R4G69u79025	R4G69u91025	R4G69u13025
1-1/4"	R4G69u83231	R4G69u12431	R4G69u62031	R4G69u79031	R4G69u91031	R4G69u13031
1-1/2"	R4G69u83238	R4G69u12438	R4G69u62038	R4G69u79038	R4G69u91038	R4G69u13038
1-3/4"	R4G69u83244	R4G69u12444	R4G69u62044	R4G69u79044	R4G69u91044	R4G69u13044
2"	R4G69u83251	R4G69u12451	R4G69u62051	R4G69u79051	R4G69u91051	R4G69u13051
2-1/4"			R4G69u62056	R4G69u79056	R4G69u91056	R4G69u13056
2-1/2"			R4G69u62063	R4G69u79063	R4G69u91063	R4G69u13063
3"			R4G69u62076	R4G69u79076	R4G69u91076	R4G69u13076
3-1/2"			R4G69u62089	R4G69u79089	R4G69u91089	R4G69u13089
4"			R4G69u62102	R4G69u79102	R4G69u91102	R4G69u13102
5"				R4G69u79126	R4G69u91126	R4G69u13126

Sizes in BLUE are non-preferred. Availability is limited and MOQ is applied

Data is strictly informative

Note: All Austenitic Stainless-Steel Fasteners may exhibit some Magnetic Properties due to the Manufacturing Process.

Refer: ISO 3506-2 Annex F