



GST NO.: 29AHZPU5620Q1ZZ

An ISO 9001:2015 Certified Company

ROYAL INDUSTRIAL SUPPLIERS

QUALITY FASTENERS SPECIALIST



8310165941 / 9959457863



sales@royalfastenersindia.com



www.royalfastenersindia.com

TECHNICAL DATA SHEET

TRUSS PHILLIPS



MATERIAL- STAINLESS STEEL

GRADE-SS304 (A2-70)

AS PER-JIS-B1111

CATALOGUE NO. R4A14T

INSTALLATION GUIDE

- VERIFY THE SCREW SIZE, LENGTH, THREAD TYPE, AND HEAD DIMENSIONS MATCH THE APPLICATION REQUIREMENT.
- INSPECT THE SCREW FOR THREAD DAMAGE, HEAD DEFORMATION, OR SURFACE DEFECTS BEFORE INSTALLATION.
- ENSURE THE MATING HOLE OR THREADED COMPONENT IS CLEAN AND FREE FROM BURRS OR DEBRIS.
- CHECK THAT THE COMPONENTS ARE PROPERLY ALIGNED BEFORE INSERTING THE SCREW.
- POSITION THE TRUSS HEAD FLAT AGAINST THE SURFACE TO PROVIDE MAXIMUM BEARING AREA.
- INSERT THE SCREW INTO THE HOLE OR MATING THREAD.
- USE THE CORRECT SIZE PHILLIPS DRIVER AS PER JIS B1111 REQUIREMENTS.
- START THREADING BY HAND TO PREVENT CROSS-THREADING.
- APPLY STEADY AND CONTROLLED TORQUE WHILE TIGHTENING THE SCREW.
- ENSURE THE LARGE LOW-PROFILE TRUSS HEAD SITS EVENLY ON THE MATING SURFACE.
- TIGHTEN THE SCREW TO THE SPECIFIED TORQUE VALUE.
- DO NOT OVERTIGHTEN, AS THIS MAY DAMAGE THE THREADS OR DEFORM THE COMPONENTS.
- VERIFY THAT THE SCREW IS SECURE AND THAT THE COMPONENTS ARE FIRMLY CLAMPED TOGETHER.
- CHECK FOR ANY GAPS, MISALIGNMENT, OR MOVEMENT IN THE ASSEMBLY.
- INSPECT THE FINAL INSTALLATION FOR PROPER SEATING, ALIGNMENT, AND SECURE FASTENING.

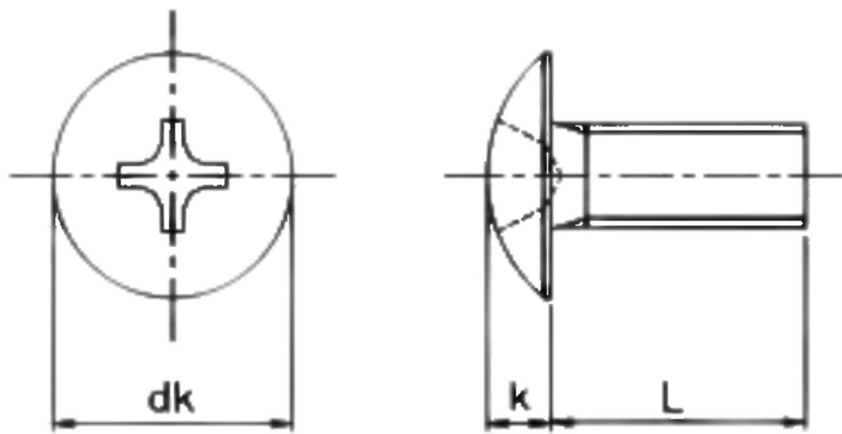

DIA	M2x0.4	M2.5x0.45	M3x0.5	M4x0.7	M5x0.8	M6x1.0	M8x1.25
dk max	4.50	5.70	6.90	9.40	11.80	14.0	17.80
dk min	4.10	5.30	6.40	8.90	11.20	13.3	17.00
K max	1.30	1.60	2.05	2.65	3.25	3.90	5.00
K min	1.10	1.40	1.75	2.35	2.95	3.50	4.60
Drive Size	PH1	PH1	PH1	PH2	PH2	PH3	PH3

Quote the PART NUMBER given below with your order/ inquiries:

All Dimensions in mm

L ↓ Dia →	M2x0.4	M2.5x0.45	M3x0.5	M4x0.7	M5x0.8	M6x1.0	M8x1.25
3	R4A14T02003	R4A14T20503					
4	R4A14T02004	R4A14T20504	R4A14T03004				
5	R4A14T02005	R4A14T20505	R4A14T03005	R4A14T04005			
6	R4A14T02006	R4A14T20506	R4A14T03006	R4A14T04006	R4A14T05006		
8	R4A14T02008	R4A14T20508	R4A14T03008	R4A14T04008	R4A14T05008	R4A14T06008	
10	R4A14T02010	R4A14T20510	R4A14T03010	R4A14T04010	R4A14T05010	R4A14T06010	
12	R4A14T02012	R4A14T20512	R4A14T03012	R4A14T04012	R4A14T05012	R4A14T06012	R4A14T08012
14	R4A14T02014	R4A14T20516	R4A14T03014	R4A14T04014	R4A14T05014	R4A14T06014	R4A14T08014
16	R4A14T02016	R4A14T20516	R4A14T03016	R4A14T04016	R4A14T05016	R4A14T06016	R4A14T08016
20	R4A14T02020	R4A14T20520	R4A14T03020	R4A14T04020	R4A14T05020	R4A14T06020	R4A14T08020
25	R4A14T02025	R4A14T20525	R4A14T03025	R4A14T04025	R4A14T05025	R4A14T06025	R4A14T08025
30	R4A14T02030	R4A14T20530	R4A14T03030	R4A14T04030	R4A14T05030	R4A14T06030	R4A14T08030
35			R4A14T03035	R4A14T04035	R4A14T05035	R4A14T06035	R4A14T08035
40			R4A14T03040	R4A14T04040	R4A14T05040	R4A14T06040	R4A14T08040
45				R4A14T04045	R4A14T05045	R4A14T06045	R4A14T08045
50				R4A14T04050	R4A14T05050	R4A14T06050	R4A14T08050
55				R4A14T04055	R4A14T05055	R4A14T06055	R4A14T08055
60				R4A14T04060	R4A14T05060	R4A14T06060	R4A14T08060

Sizes in BLUE are non-preferred. Availability is limited and MOQ is applied *Data is strictly informative*

Note: All Austenitic Stainless-Steel Fasteners may exhibit some Magnetic Properties due to the Manufacturing Process.

Refer: ISO 3506-2 Annex F